

# Plastic Folding Slide

 **SWING  
SLIDE  
CLIMB**  
Distributed By  
South Earl Pty Ltd

PFS21



A x1



B x1



C x1



D x1



E x1

**WARNING: ONLY FOR DOMESTIC OUTDOOR USE.**  
THIS PLAYSET SATISFIES ALL THE REQUIREMENTS OF THE EUROPEAN STANDARD EN 71 AND HAS BEEN CERTIFIED BY AN INDEPENDENT LABORATORY. TO GUARANTEE SAFETY, PLEASE GIVE SPECIAL ATTENTION TO THE ASSEMBLY, SAFETY, AND CARE INSTRUCTIONS DETAILED IN THIS DOCUMENT.

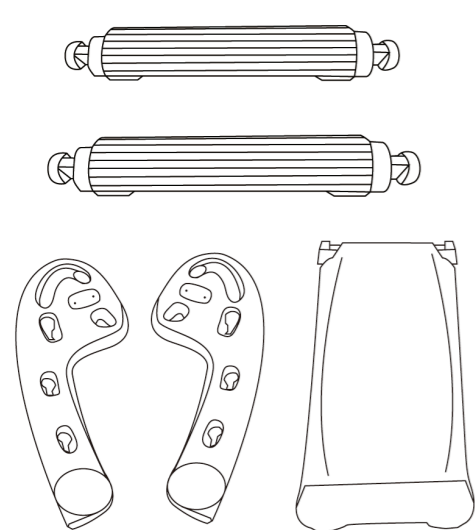

**Step 1**

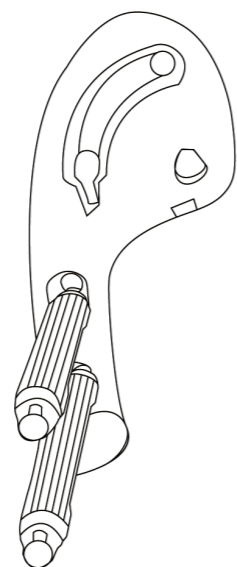

**Step 2**

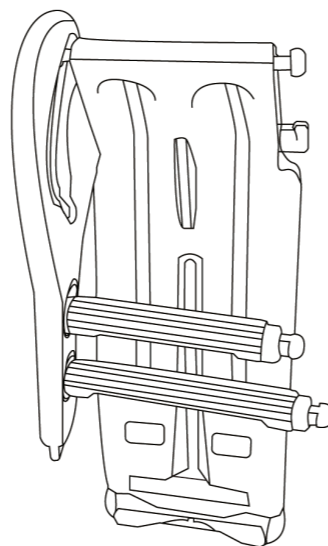

**Step 3**

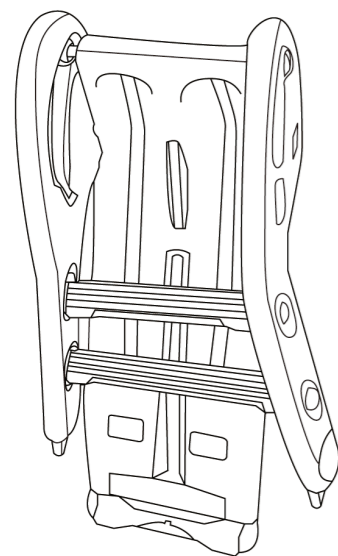

**Step 4**

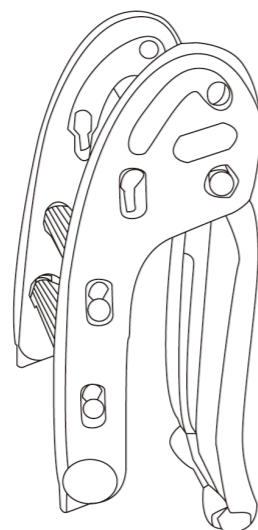

**Step 5**

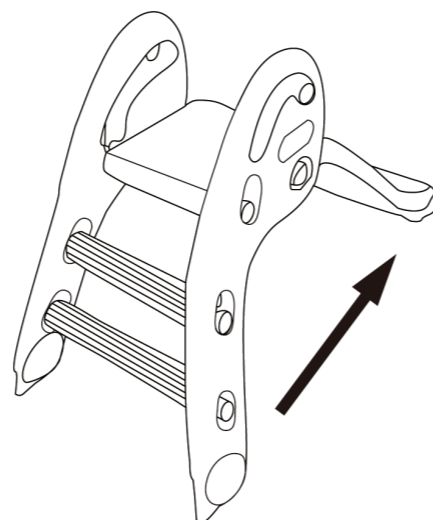

**Step 6**

## FOLDABLE SLIDE

**Warning: Only for domestic indoor and outdoor use.**

This slide satisfies all the requirements of the European standard EN 71 and has been certified by an independent laboratory. To guarantee safety, please give special attention to the assembly, safety, and care instructions detailed in this document.

### ASSEMBLY ADVICE

- Follow the instructions exactly.
- The appropriate height of starting section of the slide from the ground is 510mm.
- This product must be assembled by an adult.
- Once assembly has been completed, keep the instructions in a safe place for future reference. This can be particularly handy for identification of parts if any after sales service is required.
- Before commencing assembly, check that none of the parts are missing. If you find that you are missing a part please contact our after sales service department.
- Retain extra parts to use as spares in the future if necessary.

The dimensions given in the instructions are indicative only, they may vary according to the assembly method.

### SAFETY ADVICE

- Warning: This product is only to be used by children between the ages of 2 and 5.
- Warning: Not to be used by anyone weighing over 35kgs.
- This product is for private use at home only. Under no circumstances is it to be used in parks, schools, camp sites, hotels, public leisure areas etc.
- The slide set should be set up on a flat surface and 2 metres away from any structures or obstacles (walks, fences, trees, washing lines, cables etc).
- To avoid damage to your children's eyes, we advise that the swing should not be setup directly facing the sun.
- The slide set should be installed over impact absorbing surfaces such as sand, wood-bark chips, rubber and foam and must NOT be set up on a hard surface (concrete, tarmac etc).detail surfacing materials please refer attached consumer information sheet.
- Dispose of packaging thoughtfully.
- Do not allow children to play with packaging.
- Please see diagram at bottom left for maximum fall height of slide.

### MAINTENANCE

- All parts should be checked at least once a month.
- Check the product thoroughly for sharp edges. If any are found, replace as required.
- All parts that are under constant friction should be oiled regularly using a suitable lubricant.
- The ground on which the slide is set up should be cleared regularly. All objects such as stones or anything else that could cause injury in the case of a fall should be removed.
- It is recommended that during the winter period when the equipment is not in use, all apparatus are removed to prevent deterioration due to bad weather.
- Modifications to the original activity toy should only be carried out under instructions from the manufacturer.
- Defective parts should only be replaced in accordance with the manufacturer's instructions.
- Make regular checks on the slide, supports, joints and steps. If any parts shows sign of wear, the damaged parts should be replaced immediately.

We hope you have a safe and enjoyable time using the slide